

LOOX LED 3019

SURFACE MOUNTED UNDER CABINET LIGHT WITH HIGH LIGHT INTENSITY



24 V SYSTEM



The LED 3019 under cabinet light is the solution for illuminating work surfaces with two different installation options and powerful light intensity. It is also easy to retrofit.



- > Dimmable
- > Corner mounting possible with supplied brackets
- > Metal housing
- > High light intensity, excellent lumen output



- > Driver see page 62

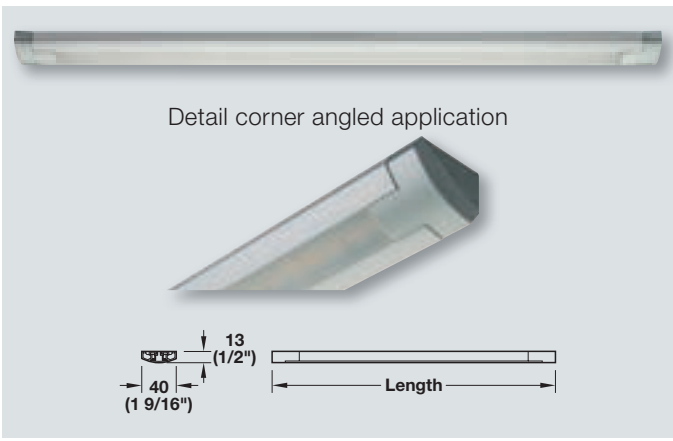

Item No.	833.76.090	833.76.091
SRP	\$180.00	\$280.00
Light color (K)	4000 (cool white)	
Length	512 (20 3/16")	812 (31 15/16")
Width	40 (1 9/16")	
Height	13 (1/2")	
Wattage (W)	11.5	19
Number of LEDs	54	90
Light output (Lm)	720	1200
Efficacy (Lm/W)	63	
Color rendering index (CRI)	80	
Material/Finish	Aluminum, silver colored anodized	
Supplied with	2 m (78 3/4") lead, Mounting accessories	

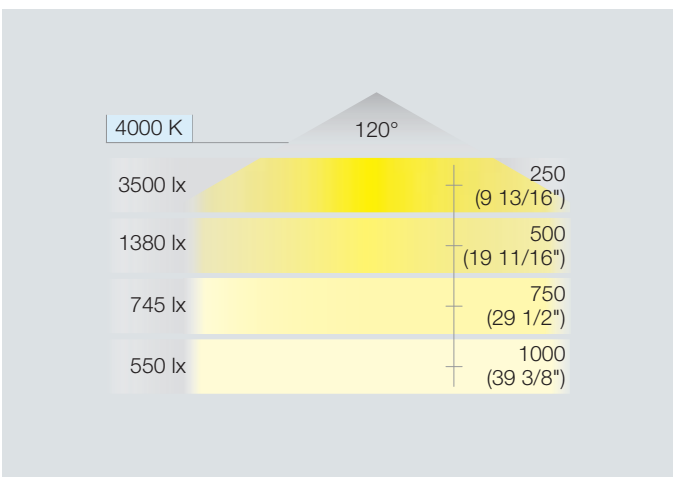

Note Loox Lights and Drivers are "Suitable for use within Closet Storage Spaces"