

RAS-ML-HDCR SERIES

HEAVY-DUTY MIXER LIFT

With design flexibility in mind, the heavy-duty chrome mixer lift can be attached to any custom made shelf and therefore will fit all cabinet sizes allowing a perfect match to your counter top or interior cabinet. Referred as the "best in the industry", the RAS-ML-HDCR provides mechanical assist and features built-in shock dampeners, adjustable spring tension and holds appliances up to 60 lbs.



SINK & BASE ACCESSORIES
Premiere
Cabinet Accessories

PRODUCT #s	DESCRIPTION	PRODUCT DIMENSIONS	FINISH	SET PER CARTON	WEIGHT PER CARTON	SUGGESTED LIST PRICE
Heavy-Duty Mixer Lift					Individual Pack	
RAS-ML-HDCR	Heavy Duty Mixer Lift	See Illustrations Next page	Chrome	1	15 lbs.	\$153.70

NOTE: Needs to be installed in full height base cabinet. Provides mechanical assistance.
CONTAINS: Right and Left Lifting arms, Hardware. **SHELF NOT INCLUDED.**

NOTE: The dimensions listed provide clearance for an item 15³/₁₆" H x 14¹/₁₆" D placed at the front edge of the shelf. Depending on your cabinet construction and your specific height and depth requirements, the 4¹/₂" dimension from the top of the cabinet to the middle of the lifting mechanism can be reduced to allow the platform to be closer to counter height, thus a greater distance below the unit in the closed position. It can also be increased to allow for items taller and deeper than the dimensions provided.

Typical Cabinet PRODUCT DIMENSIONS

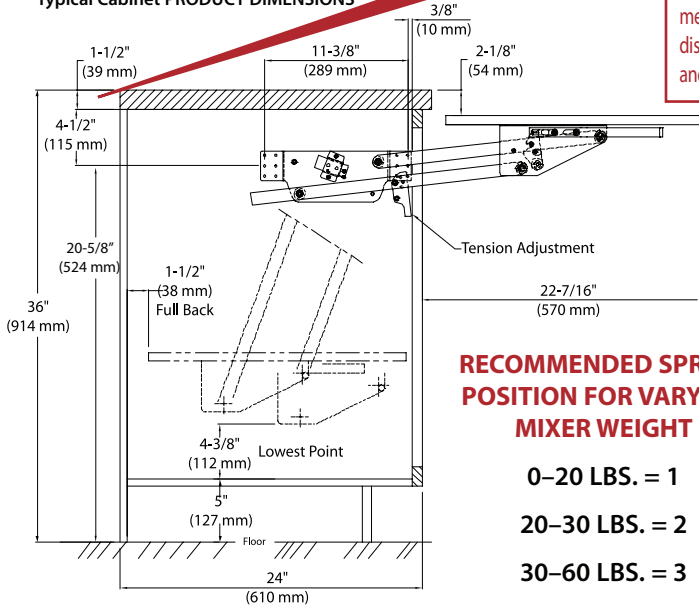

RECOMMENDED SPRING POSITION FOR VARYING MIXER WEIGHT

- 0-20 LBS. = 1
- 20-30 LBS. = 2
- 30-60 LBS. = 3

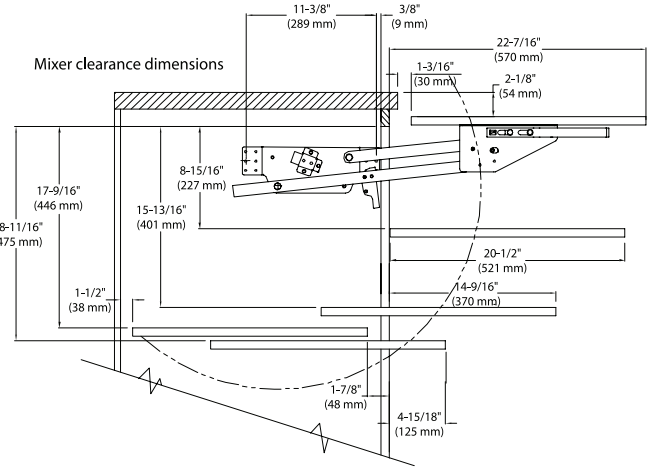

SHELF NOT INCLUDED

To determine shelf size measure the distance between mounting plates when installed minus 1¹/₄".
 Recommended length of shelf is 20¹/₂".
 Mounting plates are 1" wide.



NEW STABILIZER!



SINK & BASE ACCESSORIES

Premiere Cabinet Accessories